

OPTION We have a variety of options and much more.

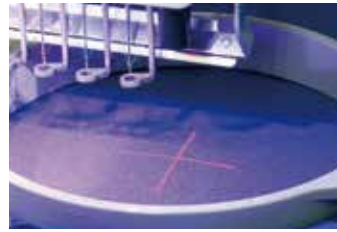

Cross Laser Pointer



Table



USB Wi-Fi dongle



Border Frame



Cap Frames



One Point Frame



Sock Frame

SPEC

Head	Needles	Embroidery Area (Length×Width)			Max Speed (rpm)	Stitch Length	Memory
		Maximum	Wide Cap Frame	Low Pro Cap Frame			
1	12	285×290mm 11.2×11.4inch	67×290mm 2.6×11.4inch	67×180mm 2.6×7.1inch	1000 850 (Cap Frame)	0.1-12.7mm	100,000,000 stitches 3,000 designs

Power Supply	Power Consumption	Frequency	Weight	Dimensions					
				L	W	H	A	B	C
Single phase 100-115V 200-230V	220W	50/60Hz	42kg 92.6lbs	642mm 25inch	745mm 29inch	734mm 29inch	250mm 10inch	480mm 19inch	580mm 23inch

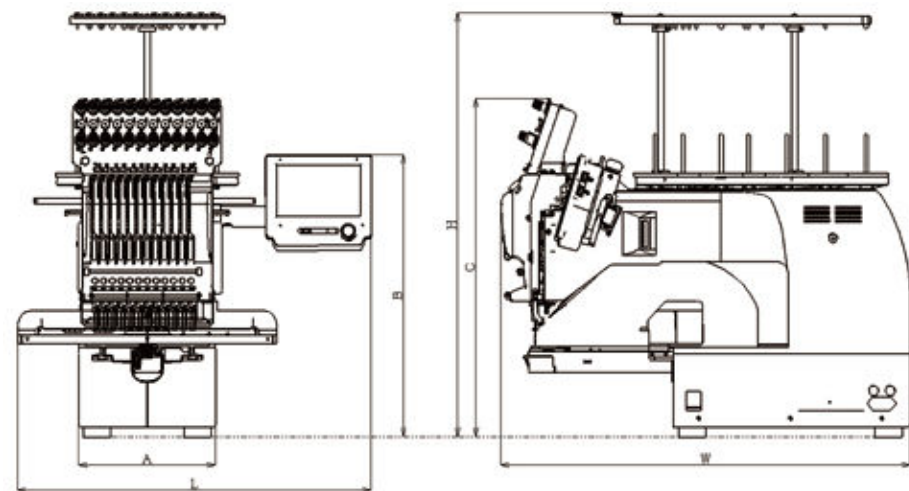

Professional single head 12 needles embroidery machine

HCS3

1201-30

AVAILABLE FOR INDUSTRIAL USE



Large workspace retained from former model allows for embroidery on large material such as bag and etc.

MADE IN JAPAN

Professional Single Head 12 needles Embroidery Machine.

Due to design concept based on industrial use, high durability, high power, and high efficiency.

▶ **Strong embroidery even thick material such as caps and thick clothes!**

Pressure foot for Each Needle

Pressure Foot : 12 pcs
(one pressure foot for every needle)
Even if a pressure foot is broken,
it is possible to use other needle.



Thread Cones with dia. 80mm available

HCS3 can use an upper thread cone with a diameter of 80mm, which can not be used with former model.



Direct Laser Pointer

Laser Pointer installed at zero needle position, vertical pinpoint laser is available.
Cross Laser Pointer as options.



*The above is Cross Laser Pointer as option.

Bed downsizing

Cross-sectional area of cylinder arm minimized in size, it can embroider for thinner tube to the edge.



HCS3

1201-30

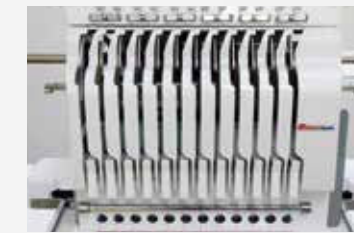

Safety Take-up Lever Cover

Adding Safety Take-up Lever Cover to improve workability.



Improved operability

LCD Panel

Added USB PORT to the front.
*USB Wi-Fi dongles can be used.

(*Option)

HAPPYLAN / LINK

Standard software HAPPYLAN/LINK enables network to control multiple machines with PC. Monogramming and design editing functions expand flexibilities and the possibilities.

Silent design

Silent and low vibration even at high speed operation. Pulse motor control makes even jump operation very quiet.

Shortening time of cutting thread on the back of fabric

Remaining thread length on the back of fabric shortened, work efficiency improves, 50% shorter than former model.

Cap Embroidery 10mm from Brim

Optional parts allow embroidery position 10mm from cap brim.
"X direction 110mm" *Standard model 15mm from cap brim.

