

JACK 杰克

快速服务 100%



杰克缝纫机股份有限公司
JACK SEWING MACHINE CO.,LTD.

使用，和加油 和维护

使用前请仔细阅读

使用前

应向油杯内加油；将电机后的旋钮推入转几转，刀片应能上下灵活移动。

—— 注意 ——

当心刀片快口伤人。操作时请使用木手柄推动机器，搬动机器时，请使用提手柄。

维护

(1) 每星期两次用风管或风箱把马达和磨刀器上的绒毛吹掉。(2) 每星期一次取下前盖将丝杆上的绒毛弄干净。(3) 每天至少一次取下刀片，用槽子清洗器刀槽清理干净。(4) 请勿向底板滚轮加油。(5) 若轮子滚不动，请拆下清洗。

—— 注意 ——

未装刀片时切勿磨刀，以免造成机器损坏。

磨刀时

请放下压脚，用力慢慢地按下磨刀手柄。如果轧死，请抬起拨叉，从新再来几次后，你便会知道怎样的轻重最适合。

Operation, Lubrication and care

Before operaring machine, read this page carefully.

Before operaring the motor, be sure that electric supply voltage and current are the same as stamped on the nameplate. Fill oil cup. Push in turning knob and turn the machine over a few revolutions by hand to see if the knife moves easily.

WARNING

This machine is equipped with a sharp knife. Keep hands away from the knife area at all times. Use control levers and handles only when operating or handling machine.

CARE OF MACHINE

Use air hose or bellows with proper eye shields and blow lint out of motor and sharpener twice a week. Remove cover over cam and clean out lint arround screw mechanism in sharpener once a week. Remove knife and clean slides with slot cleaner at least once a day. To prevent undue accumulation of lint, do not oil plate rollers. If rollers stick. romove from plate and wash in cleaning solvent.

WARNING

Do not operate sharpener without knife in machine or the sharpener will be damaged.

TO SHARPEN THE KNIFE

Take the machine out of the lay. Drop pressure foot by means of pressure foot lever located next to machine operating handle. Press release lever downward with a slow, firm pressure to engage sharpening emchanism. Too fast lever action may cause lever to lock. If this occurs, lift latch lever and start over. After a few tries you will feel correct operating pressure.

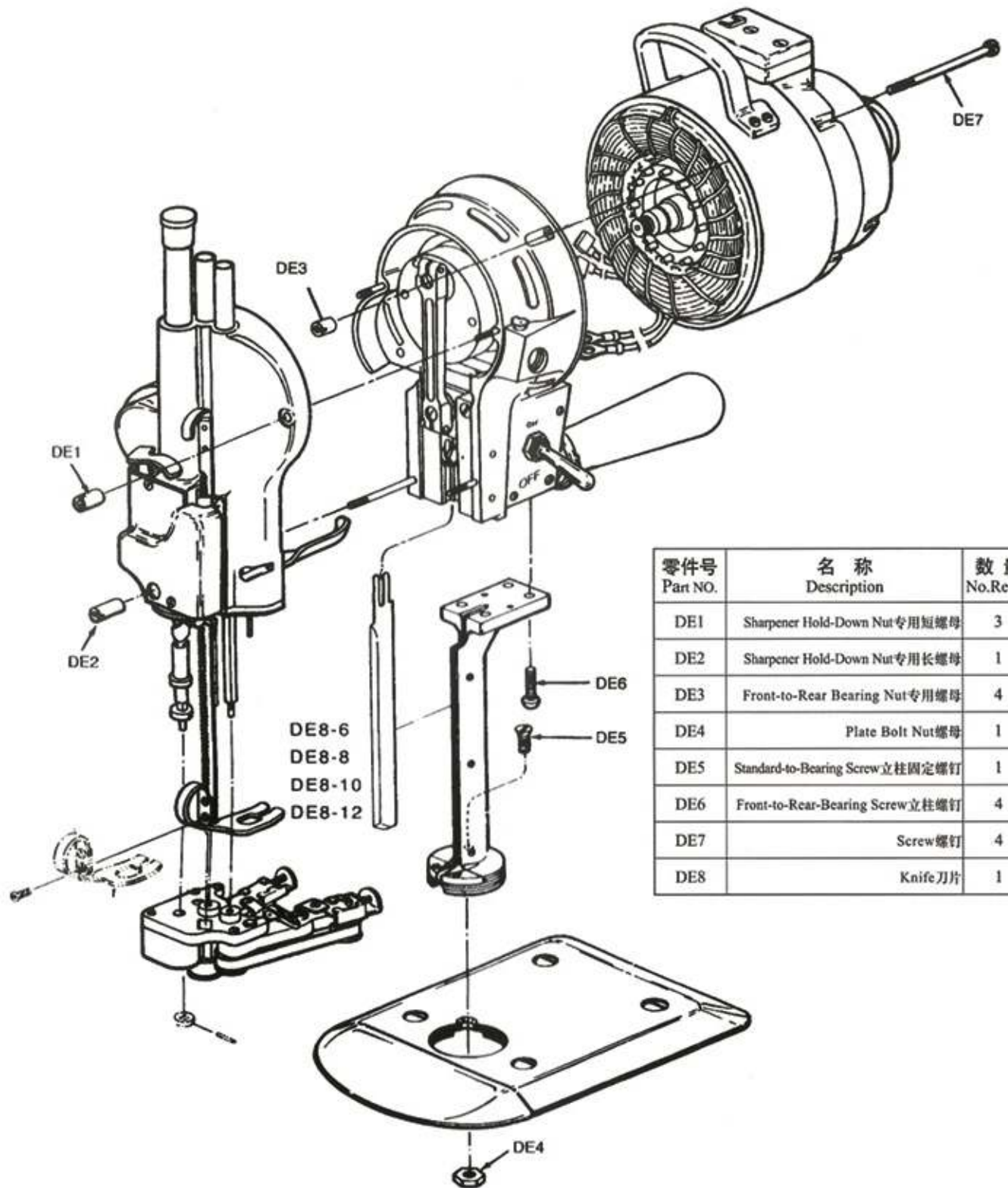

零件号 Part NO.	名称 Description	数量 No. Req'd
DE1	Sharpener Hold-Down Nut 专用短螺母	3
DE2	Sharpener Hold-Down Nut 专用长螺母	1
DE3	Front-to-Rear Bearing Nut 专用螺母	4
DE4	Plate Bolt Nut 螺母	1
DE5	Standard-to-Bearing Screw 立柱固定螺钉	1
DE6	Front-to-Rear-Bearing Screw 立柱螺钉	4
DE7	Screw 螺钉	4
DE8	Knife 刀片	1

单相马达组

Single-Phase Motor Assemblies

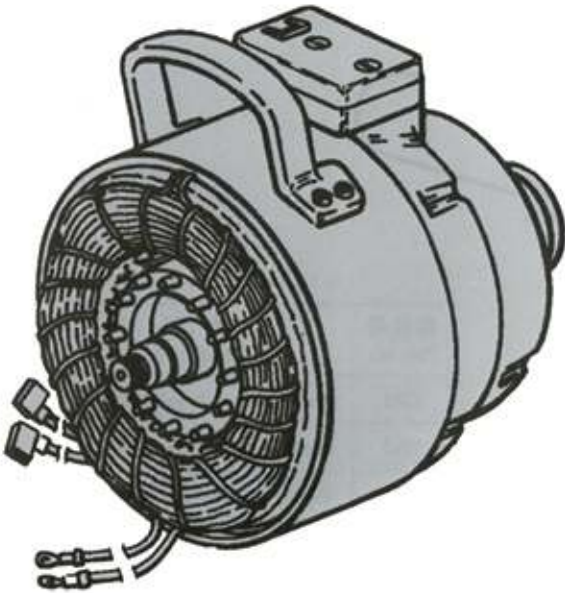

零件号 Part NO.	名称 Description	数量 No. Req'd
DE9	Terminal Wire Tubing绝缘器	1
DE10	Stator with Band电机定子组件	1
DE11	Rotor and shaft电机转子组件	1
DE12	Carrying Handle提手柄	1
DE13	Screw提手柄螺钉	4
DE14	Terminal Wire Tubing引线管	1
DE15	Reac Ball Bearing单列向心球轴承	2
DE16	Terminal线耳	2
DE17	Rear Bearing House后机匣	1
DE18	Terminal Block插头组件	1
DE19	Attachment Plug电源插头组件	1
DE20	Screw插头组件螺钉	2
DE21	Cutout switch Mount离心开关罩	1
DE22	Automatic Cutout离心开关切断器	1
DE23	Automatic Cutout Swith离心开关组件	1
DE24	Shaft Cover For Cutout离心开关轴套	1
DE25	Screw离心开关罩螺钉	2
DE26	Screw离心开关盖螺钉	2
DE27	Cover for Cutout离心开关盖	1
DE28	Rotor Fan风轮	1
DE29	Leading sping Washer止动垫圈	1
DE30	Clutch Nut电机转子圈	1
DE31	Retaining Ring轴用弹性挡圈	1
DE32	Fan Cover风轮盖	1
DE33	Screw风轮盖螺钉	2
DE34	Clutch Sping弹簧	1
DE35	Turning Knob旋钮	1

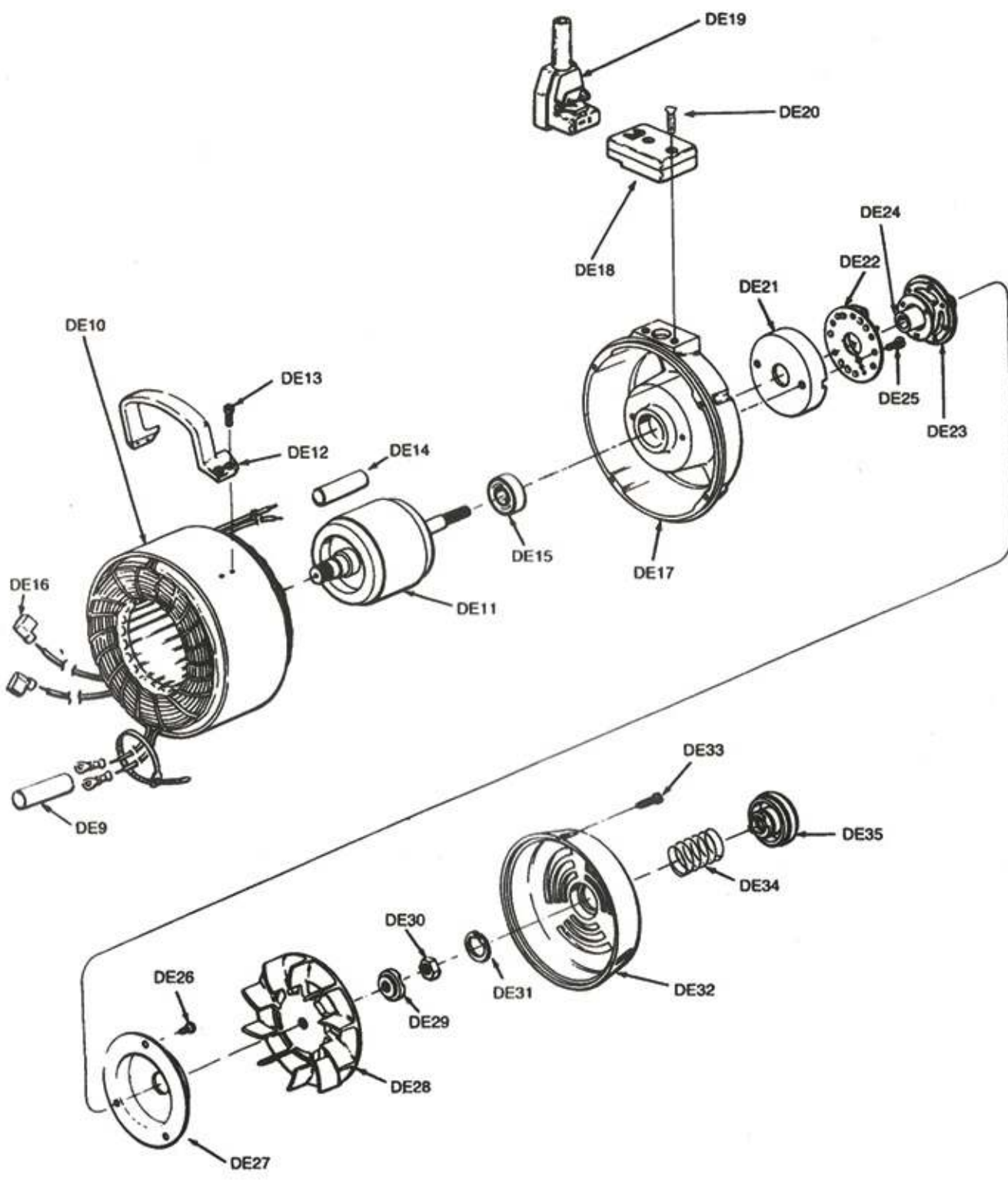

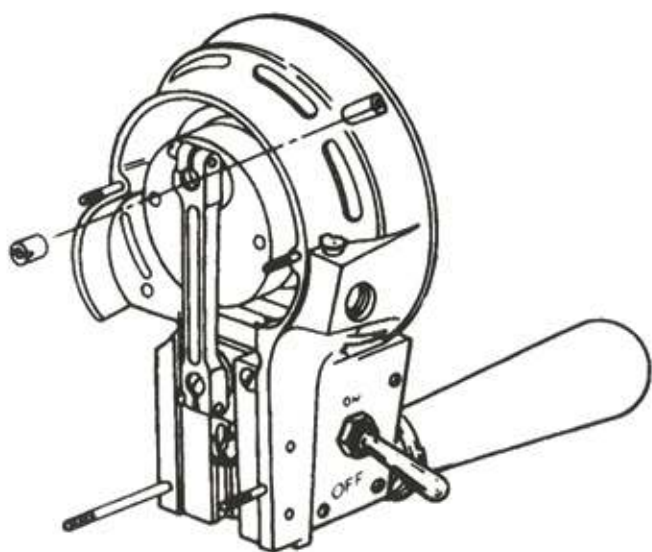

前轴承套组

Front Bearing Housing Assembly

零件号 Part NO.	名称 Description	数量 No.Req'd
DE36	Screw电容器螺钉	6
DE37	Screw电容压板螺钉	1
DE38	Capacitor Cover电容器罩	1
DE39	Capacitor启动电容	1
DE40	Cover for Capacitor电容器外套	1
DE41	Spring for Capacitor电容压板	1
DE42	Shaft Lock Nut六角螺母	1

零件号 Part NO.	名称 Description	数量 No.Req'd
DE43	Front Bearing Housing前机匣	1
DE44	Bearing单列向心球轴承	1
DE45	Front Ball Bearing Retainer前机匣轴承挡圈	1
DE46	Screw轴承挡圈螺钉	4
DE47	Screw内六角平端紧定螺钉	3
DE48	Washer垫圈	9
DE49	Nut螺母	3
DE50	Crank偏心轮	1
DE51	Stud,upper双头螺栓	2
DE52	Stud,Lower Mounting双头螺栓	1
DE53	Stud,Lower Mounting双头螺栓	1
DE54	Guide Adjustment Nut支撑螺套	3
DE55	Shaft for Ball Bearing传动销	1
DE56	Seated CrankBall Bearing 单列向心球轴承	1
DE57	Lock Nut for Shaft传动销螺母	1
DE58	Crank Ball Bearing Lock Nut轴承挡圈	1
DE59	Connecting Rod连杆	1
DE60	Screw连杆螺钉	2
DE61	H Guide导轨	1
DE62	Cross Head中心滑轮	1
DE63	Wrist Pin从动销	1
DE64	Wrist Pin Felt Pad油绳	1
DE65	Connecting Rod Washer垫片	1
DE66	Screw半端紧定螺钉	1
DE67	Guide Washer垫片	1
DE68	Screw圆柱头内六角螺钉	6
DE69	Knife Lock Washer固定刀垫片	1
DE70	Screw方头螺钉	1
DE71	Screw圆柱头内六角螺钉	2
DE72	Handle Bracket力板	1
DE73	Screw内六角螺钉	1
DE74	Screw for Handle Bracket力板螺钉	1
DE75	Operating Handle Lock Nut木手柄锁紧螺母	1
DE76	Operating handle木手柄	1
DE77	Switch电机开关	1
DE78	Switch Base开关盖	1
DE79	Screw开关盖螺钉	3
DE80	Oiling device油杯组件	1
DE81	Oil Tube油杯座	1
DE82	Eyelet空心铆钉	1
DE83	Cover for Oil Tube油杯盖盖板	1
DE84	Long Wicking油绳	3
DE85	Screw油杯座盖板螺钉	4
DE86	Screw油杯座螺钉	2
DE87	Circle密封圈	2
DE88	Windows for oil油窗	1
DE89	Oil tube cover油杯座盖	1
DE90	Oil Hole Cover油杯	1

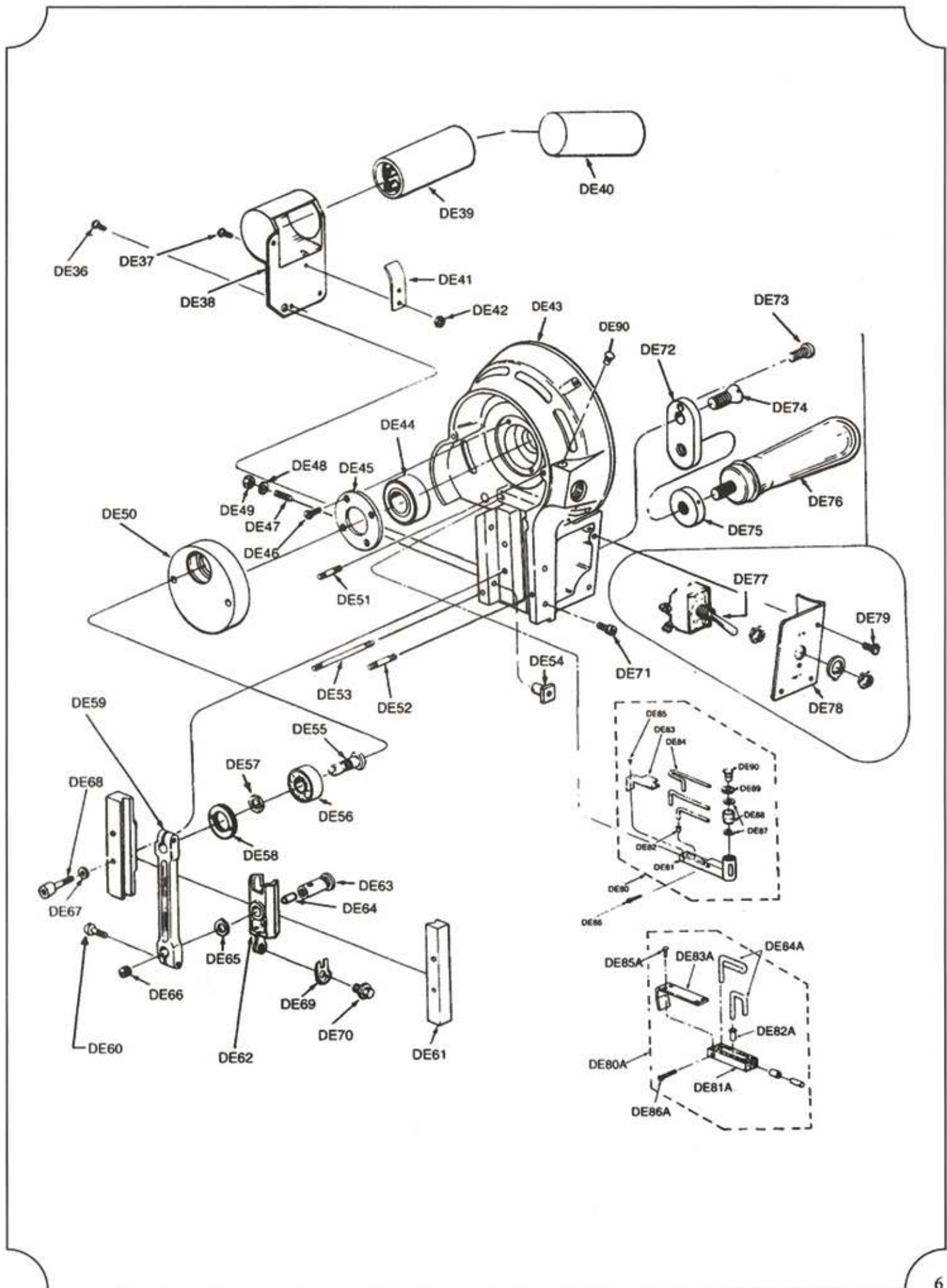



零件号 Part NO.	名称 Description	数量 No.Req'd
DE91	Standard立柱	1
DE92	Knife Slide刀壳组件	1
DE93	Throat Plates脚板	2
DE94	Taper pin脚板定位销	2
DE95	Screw脚板螺钉	2
DE96	Screw刀壳螺钉	3
DE97	PlateWing导板	1
DE98	Plate底板	1
DE99	Runner Roller all set滚轮组件	4
DE100	Roller Shell滚轮衬套组件	4
DE101	Rubber Mounted Roller橡胶安装座组件	4
DE102	Clamp Screw for Roller底板压轴螺钉	12
DE103	Hinge Pin导板连接轴	2
DE104	Plate Wing Spring导板弹簧	2
DE105	Lock Washer.#8止动垫片	2

刀夹底盘组

Standard and Beseplate Assembly

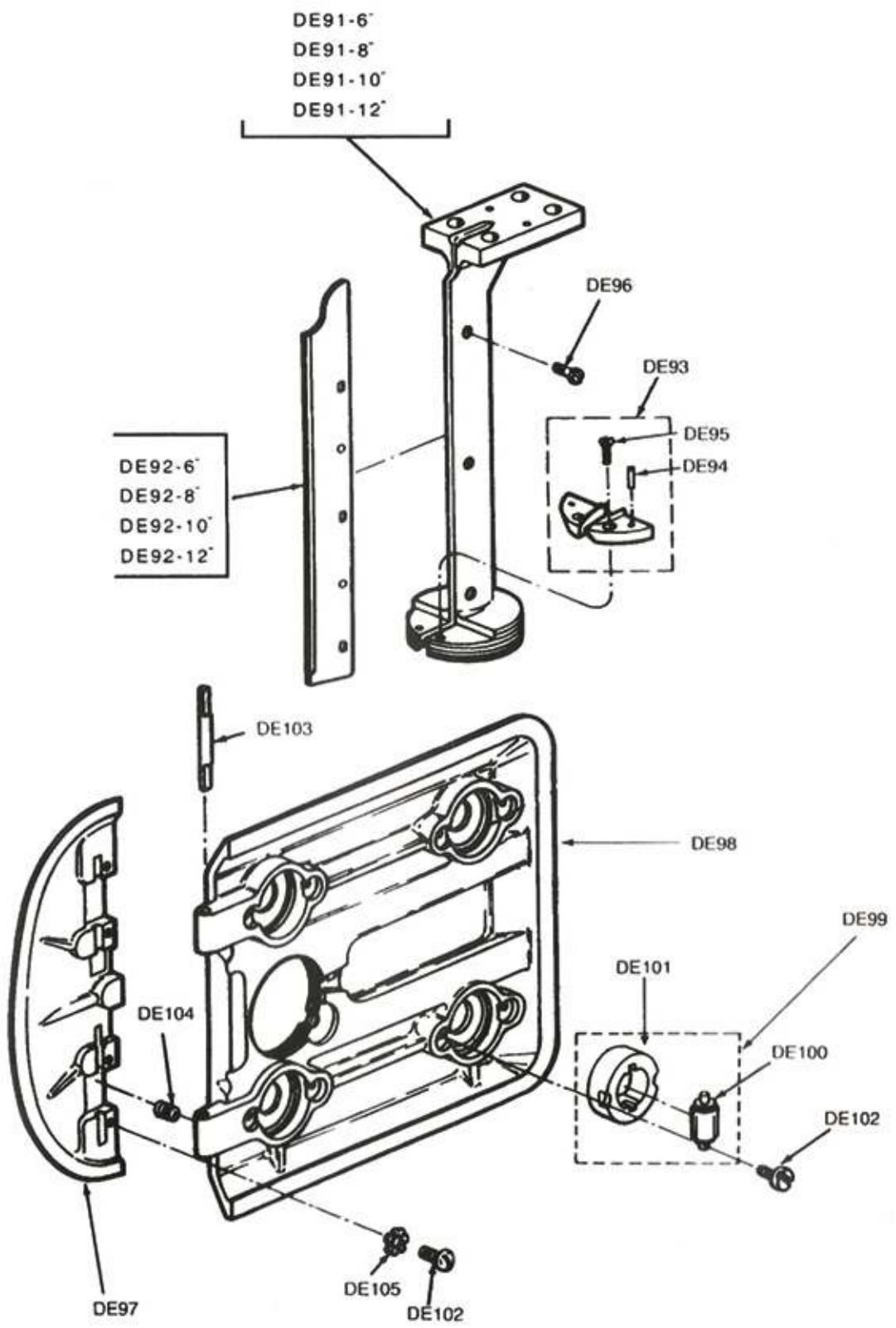

磨刀器组

背面 FRONT

Front Sharpener Housing Assembly

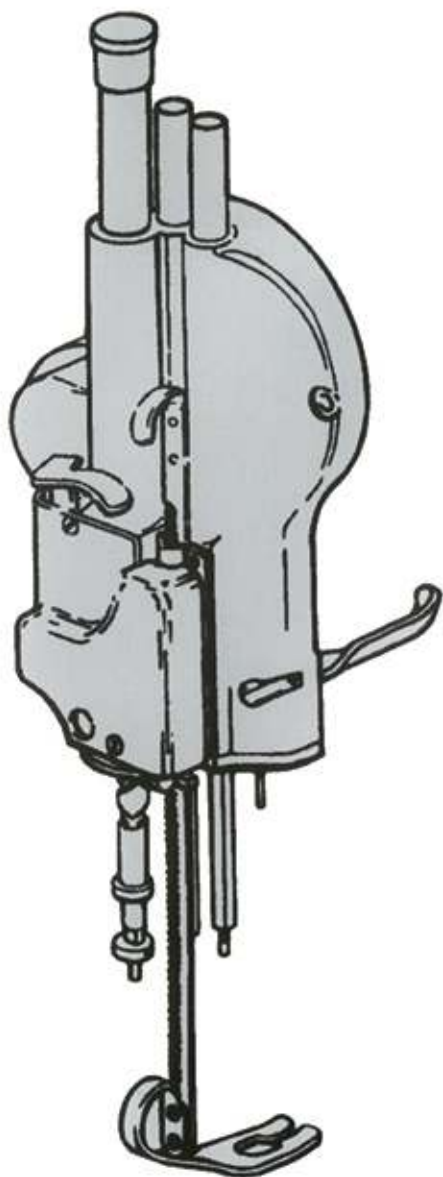

零件号 Part NO.	名称 Description	数量 No.Req'd
DE106	Cap of Tube塑料帽	1
DE107	Stop Nut for Screw Shaft锁紧螺母	1
DE108	Nut for Screw Shaft丝杆上螺母	1
DE109	Thrust washer for Nuts轴承片	3
DE110	Thrust Ball Bearing轴承组件	3
DE111	L.H.Nut for screw Shaft左向螺母	1
DE112	R.H.Nut for screw Shaft右向螺母	1
DE113	Screw Shaft双向丝杆	1
DE114	Collar for Fxtension双向丝杆挡圈	1
DE115	Release Lever with Cam磨刀手柄组件	1
DE116	Sharpener Housing With Bushings and Tubes磨刀机匣组件	1
DE117	Spring washer for Release Leceer弹性垫圈	1
DE118	Release Lever With Cam磨刀手柄	1
DE119	Cam偏心块	1
DE120	Screw磨刀手柄铆钉	1
DE121	Set Screw for Cam圆柱端紧定螺母	1
DE122	Screw for Release Lever磨刀手柄活动螺钉	1
DE123	Latch for Cam拨叉	1
DE124	Spring for Latch拨叉弹簧	1
DE125	Screw for Latch拨叉定位螺钉	1
DE126	Bearing for Cam Shaft发条销上轴衬	1
DE127	Bearing for Cam Shaft发条销下轴衬	1
DE128	Shaft for Cam发条销	1
DE129	Cam Spring锁紧发条	1
DE130	Cam Shaft Spring Screw发条销限位螺钉	1
DE131	Pressure Foot Lever压脚放松手柄	1
DE132	Spring for Pressure Foot Lever放松手柄弹簧	1
DE133	Pressure Foot Lever Screw放松手柄螺钉	1
DE134	Spacer for Knife Guard Lock Bracket扩齿托架垫片	1
DE135	Knife Guard Lock Bracket Complete压脚托架	1
DE136	Lock for Pressure Foot压脚定位板	1
DE137	Spring for Knife Guard Lock护齿弹簧	1
DE138	Nut for pressure Foot Lock锁紧螺母	1
DE139	Knife Guard Lock Bracket Only支持桩子	1
DE140	Screw for Knife Guard Lock护齿螺钉	1
DE141	Screw压脚托架螺钉	4
DE142	Pressure Foot Lock Bracket Complete压脚托架组件	1
DE143	Cover Over Cam前罩	1
DE144	Screw前罩下螺钉	1
DE145	Screw前罩上螺钉	1
DE146	Screw for Pressure Foot Shoe压脚螺钉	2
DE147	Pressure Foot shoe压脚	1
DE148	Screw压脚杆提手柄螺钉	2
DE149	Lift Handle for Knife Guard Rad压脚杆提手柄	1
DE150	Knife Guard Rod压脚杆	1

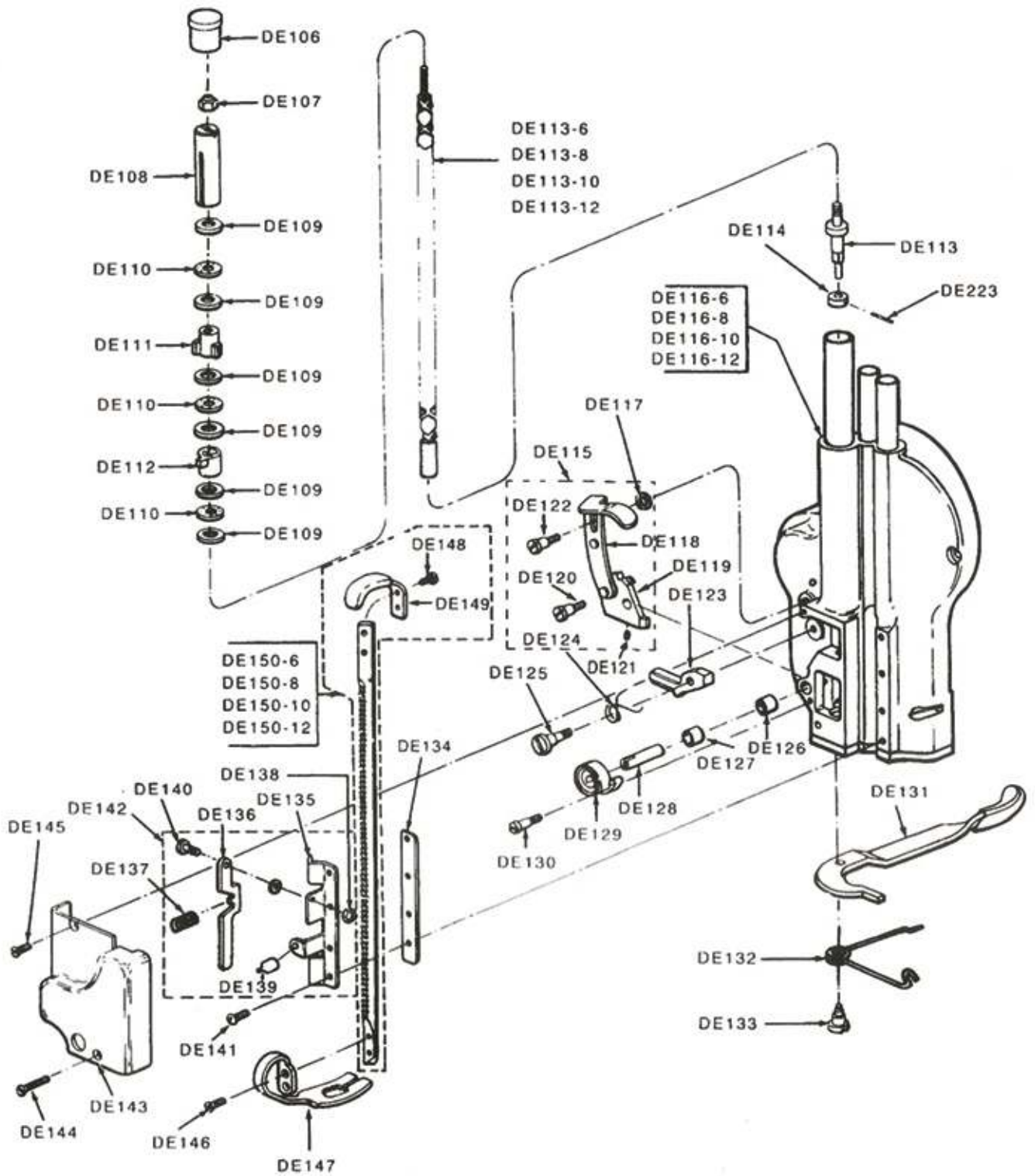

磨刀器组

背面 BACK

Front Sharpener Housing Assembly



零件号 Part NO.	名称 Description	数量 No.Req'd
DE151	R.H.Follower Nut随动螺母	1
DE152	L.H.Follower Nut随动左螺母	1
DE153	Square Shaft方导杆	2
DE154	Tube for Square Shaft方导杆管套	2
DE155	Tube for Square Shaft丝杆管套	1
DE156	Sharpener Housing磨刀机匣	1
DE157	Felt Pad for Oil Retainer-Idler Gear从动斜齿轮油盖毛毡	1
DE158	Oil Retainer-Idler Gear从动斜齿轮油盖	1
DE159	Screw斜齿轮油盖螺钉	2

零件号 Part NO.	名称 Description	数量 No.Req'd
DE160	Shaft for Grank斜齿轮芯轴	1
DE161	Idler Gear斜齿轮	1
DE162	Gear and Shaft斜齿轮轴	1
DE163	Bell Grank斜齿轮传动机匣	1
DE164	Ball Bearing for Grank单列向心球轴承	2
DE165	Spacer for Bell Bearings斜齿轮轴衬圈	1
DE166	Retaining Ring for Bell Crank孔用弹性挡圈	1
DE167	Drive Pulley with Driver摩擦轮组件	1
DE168	Bearing for Bell Grank斜齿轮芯轴衬套	1
DE169	Washer for Shaft垫片	1
DE170	Retaining Ring for Shaft轴用弹性挡圈	1
DE171	Pin for Bell Grank顶针	1
DE172	Bearing for Drive Shaft斜齿轮传动杆上轴衬	1
DE173	Thrust washer 15 牙斜齿轮垫圈	2
DE174	Spiral Gear牙斜齿轮	1
DE175	Bearing for Drive Shaft齿轮传动杆中轴衬	1
DE176	Bearing for Drive Shaft齿轮传动杆下轴衬	1
DE177	Key键	1
DE178	Drive Shaft with Gear齿轮传动杆	1
DE179	Lock Nut for Shaft六角螺母	1
DE180	Pin for Sharpener Housing推杆档柱	1
DE181	Spring for Bell Grank支撑弹簧	1
DE182	Bearing for Gears 20 牙齿轮衬轴	2
DE183	Spur Gear 20 牙齿轮	2
DE184	Thrust Washer for Bottom Plate底座垫圈	2
DE185	Push Rod推杆	1
DE186	Roll for Push Rod推杆定位销	1
DE187	Bearing for Screw Shaft丝杆轴套	1
DE188	Bottom Plate磨刀机匣底板	1
DE189	Oil Pad and Holder油垫座	1
DE190	Spreader Pin分隔块	1
DE191	Screw分隔块螺钉	1
DE192	Screw磨刀机匣底板螺钉	3
DE193	Screw油垫座螺钉	2
DE194	Rivet空心铜铆钉	4
DE195	H.Oil Pad油垫座左右垫毡	1

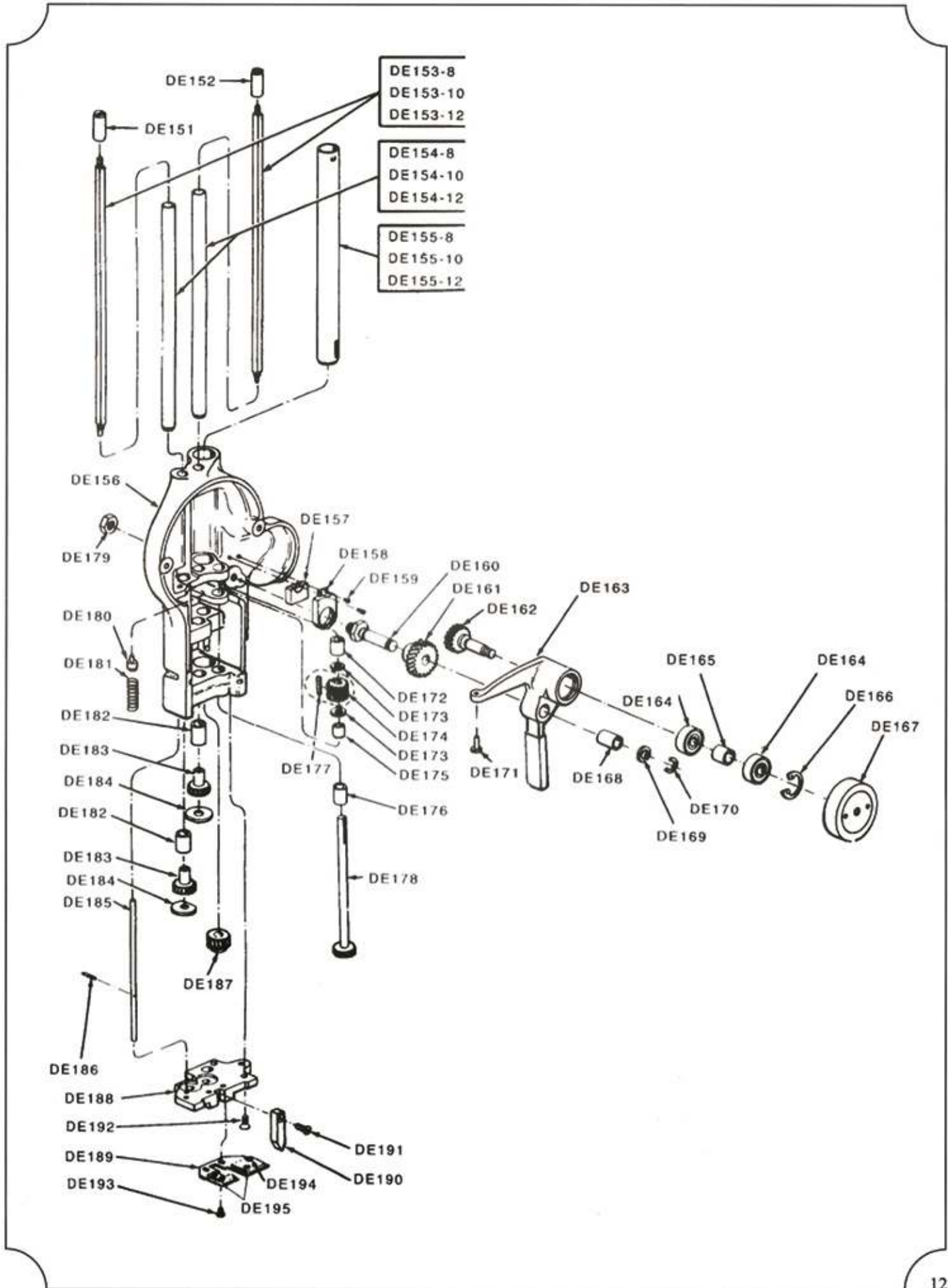

下齿轮托架组

Lower Gear Bracket Assembly

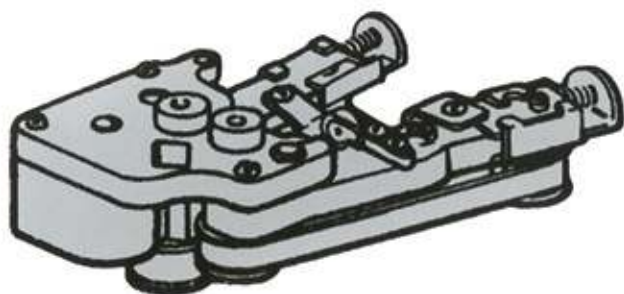

零件号 Part NO.	名称 Description	数量 No.Req'd
DE196	L.H.Shaft Extension 8牙齿轮轴	1
DE197	R.H.Shaft Extension 滑轮轴	1
DE198	Adjusting Screw 磨刀架盖板螺钉	1
DE199	Screw 半圆头螺钉	1
DE200	Screw 半圆头螺钉	3
DE201	Gear Cover 磨刀架盖板	1
DE202	Screw 挡片螺钉	2
DE203	Guide Back of Standard 挡片	1
DE204	Spring for Arm 夹紧臂弹簧	1
DE205	Clamping Arm for Shoe 夹紧臂	1
DE206	Screw for Clamping Arm 夹紧臂螺钉	1
DE207	Screw 紧定滚轮螺钉	4
DE208	Stabilizer 紧定滚轮组件	2
DE209	Nut for Sharpener Shoe Screw 六角螺母	2
DE210	Screw.#4-36×3/16 Fillister Head 圆柱头螺钉	2
DE211	Intermediate Gear 双联齿轮	1
DE212	Lower Gear Bracket with Cover 磨刀架	1
DE213	Wear Plate 耐磨板	2
DE214	Spring for Pulley slide 滑动小轮弹簧	2
DE215	R.H.Slide with Pulley 左滑动小轮组件	1
DE216	Slide with Pulley 右滑动小轮组件	1
DE217	Gear on Screw Shaft 24牙齿轮	1
DE218	Grease Plug 平端紧定螺钉	1
DE219	Bearing for Screw Shaft 双向丝杆衬套	1
DE220	Bearing for Intermediate Gear 双联齿轮衬套	1
DE221	Bearing for Shaft Extension 传动小轮衬套	2
DE222	Front Pulley for Belt 传动小轮	1
DE223	Roll Pin 弹性圆柱销	2
DE224	Neoprene Band for Pulley 传动小轮橡胶套	2
DE225	R.H.Pre-set Sharpener Shoe(Only) 右磨刀垫	1
DE226	L.H.Pre-set Sharpener Shoe(Only) 左磨刀垫	1
DE227	Washer 磨刀垫螺钉垫片	4
DE228	R.H.Pre-set Sharpener Shoe 右磨刀垫组件	1
DE229	L.H.Pre-set Sharpener Shoe 左磨刀垫组件	1
DE230	Bushing for sharpener Shoe 磨刀垫螺钉衬套	2
DE231	R.H.Sharpener Shoe Spring 右弹簧	1
DE232	L.H.Sharpener Shoe Spring 左弹簧	1
DE233	Screw for Sharpener shoe 磨刀垫螺钉	2
DE234	Shon Screw 内六角锥端紧定螺钉	1
DE235	Jam Nut 小六角较扁母	1
DE236	Belt 砂带	2

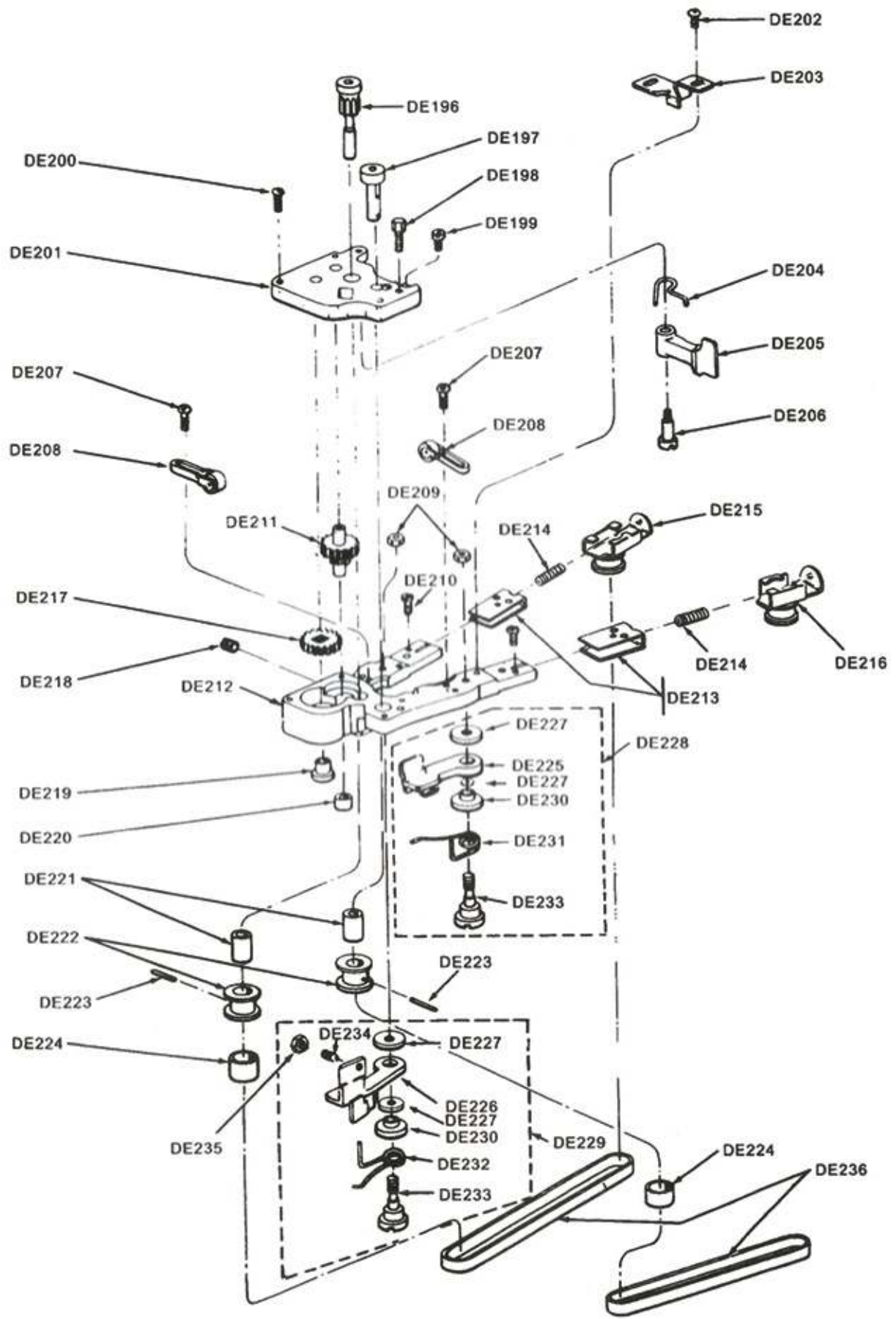

附件 Accessories

编号 Part NO.	名称 Description	数量 No.Req'd
DE237	Wrench 六角扳手	1
DE238	Slot Cleaner 槽子清洗器	1
DE239	Square Sleeve 四角套筒	1
DE240	Attachment & Wire Plug 电源线插头组件	1
DE8	Knife 刀片	1
DE236	Belt 砂带	10

12"、10"、8"、6" 不同尺寸零件表 Different Size Parts List

图号 Part NO.	名称 Description	尺寸规格 Size			
		12"	10"	8"	6"
DE150	Knife Guard Rod 压脚杆	414	364	314	314
DE154	Tube for Square Shaft 方导杆管套	295	246	195	195
DE155	Tube for Screw Shaft 丝杆管套	294	244	194	194
DE153	Square Shaft 方导杆	347	294	247	247
DE113	Screw Shaft 双向丝杆	419	369	319	269
DE92	Knife Slide 刀壳组件	319	269	219	169
DE8	Knife 刀片	344	294	244	194
DE91	Standard 立柱	324	274	224	174

地址：浙江省台州市椒江区机场南路15号

No. 15 South Airport Road, Jiaojiang District, Taizhou City, Zhejiang Province

电话(Tel): 0086-576-88177782 88177767

传真(Fax): 0086-576-88177758

网站: www.chinajack.com